

# Oil Pump Type BFP 10/11 Size 3, 5



## General Data Sheet

For specific information on this product, please contact Danfoss Burner Components

### Identification

**BFP 11 L5 L** (Example)

- L Left hand nozzle outlet
- R Right hand nozzle outlet
- 3 Capacity 24 l/h
- 5 Capacity 42 l/h
- R Clockwise rotation
- L Counterclockwise rotation
- 0 Without solenoid valve
- 1 With one solenoid valve
- 1 Ring filter, pressure adjustment on side

Capacity at 4.3 cSt., 10 bar, 2800 min<sup>-1</sup>.

### Note!

Shaft rotation, location of nozzle outlet and other connections are seen from shaft end.

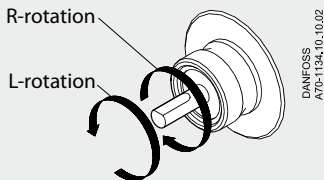

### Connections

Example shows BFP 11 L5L.

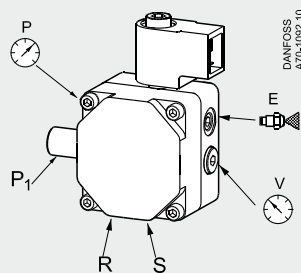

- P<sub>1</sub> Pressure adjustment
- S Suction inlet G 1/4
- R Return outlet G 1/4
- E Nozzle outlet G 1/8
- P Pressure gauge port G 1/8
- V Vacuum gauge port G 1/8
- H Filter

BFP 10/11 sizes 3, 5 oil pumps are designed for small/medium-sized domestic oil burners up to 42 l/h.

### Application and features

- Light oil and kerosene
- 1 or 2-pipe operation
- 1-stage
- Built-in pressure regulator
- Solenoid valve cut-off (BFP 11)
- Ring filter

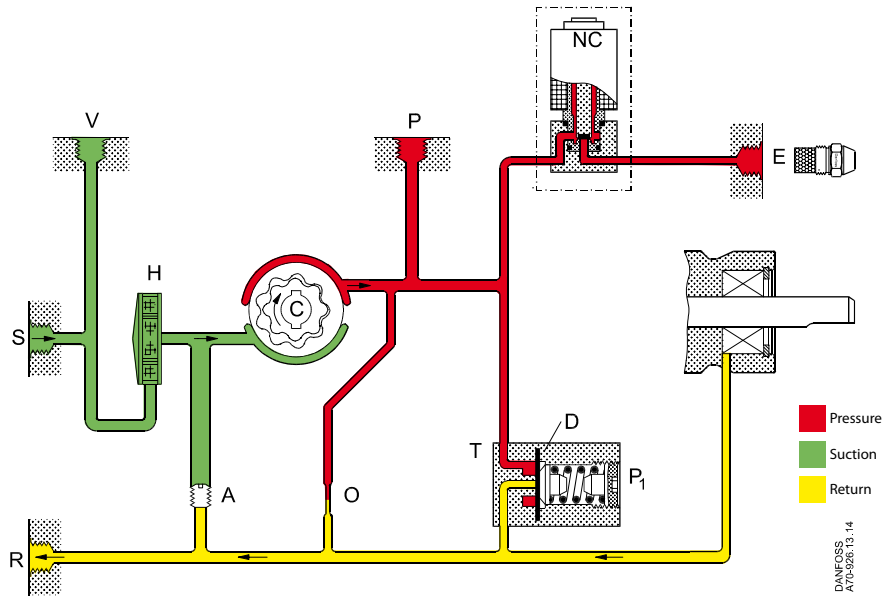

### Function

From the suction inlet (S) oil is drawn through the filter (H) to the gear set, where the pressure is increased. When voltage is applied to the NC-valve (normally closed), it opens and releases oil to the nozzle outlet.

By means of the diaphragm (D) in the pressure regulator (T) the pressure is kept constant at the value set on adjustment screw (P<sub>1</sub>).

In 2-pipe systems the excess oil is led back to the return outlet (R) and the tank. In 1-pipe systems with plugged return outlet (R) and a bypass washer (horseshoe) mounted on screw (A), the oil is returned internally to the gear set (see details in below figure).

### Change-over between 1 and 2-pipe operation. Filter replacement

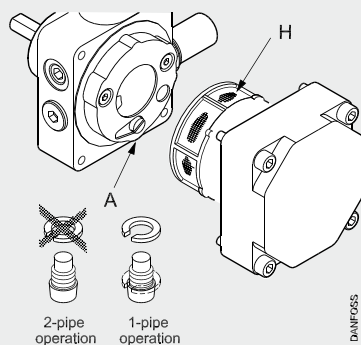

2-pipe operation:  
Screw (A) without  
bypass washer

1-pipe operation:  
Bypass washer  
fitted on screw (A)

### Cut-off function, solenoid valve (BFP 11)

When the burner stops, the voltage to the NC-valve is cut off and the oil flow to the nozzle outlet is cut off immediately. BFP 10 has no solenoid valve. In systems using this pump, a separate cut-off valve must be fitted in the nozzle line.

### Bleeding

In 2-pipe systems the pump is self-priming, i.e. bleeding is performed via the constriction (O) to the return outlet (R).

In 1-pipe systems with plugged return outlet (R), bleeding must be performed through the nozzle outlet (E) or the pressure gauge port (P).

### Warranty

For pumps used outside the stated technical data and used with oil containing abrasive particles Danfoss cannot give any warranty.

## Technical Data

BFP 10/11	Size	3	5
Viscosity range (measured in suction inlet) <sup>1)</sup>	mm <sup>2</sup> /s (cSt.)	(1.3) 1,8 - 12.0	
Filter area/mesh	cm <sup>2</sup> /μm	13/200	
Pressure range <sup>2)</sup>	bar	7-15	7-20
Factory setting	bar	10 ±1	
Max. pressure in suction inlet/return outlet	bar	2	
Speed	min <sup>-1</sup>	2400-3450	1400-3450
Max. starting torque	Nm	0.1	0.12
Ambient/transport temperature	°C	-20 to +70	
Temperature of medium	°C	0 to +70	
Coil power consumption	W	9	
Rated voltage (other voltages on request)		220/240V, 50/60 Hz	
Coil enclosure		IP 40	
Shaft/neck		EN 225	

<sup>1)</sup> Special pumps for Kerosene

<sup>2)</sup> Max. 12 bar at 1.3 cSt., max. 15 bar at 1.8 cSt.

### Nozzle capacity

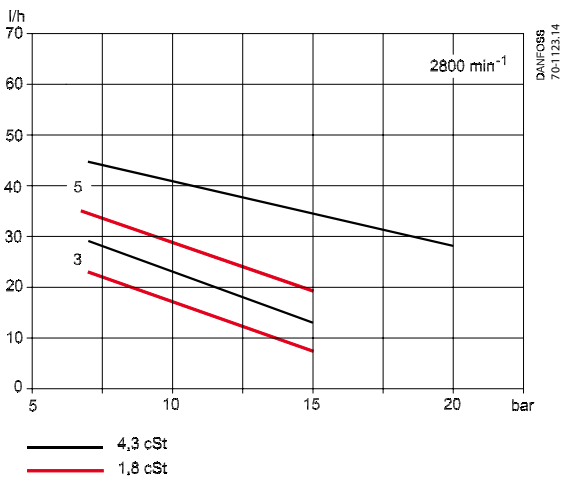

### Operating torque

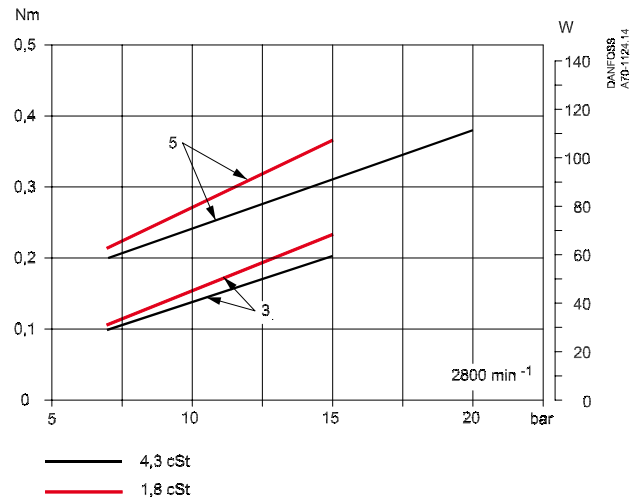

### Power consumption

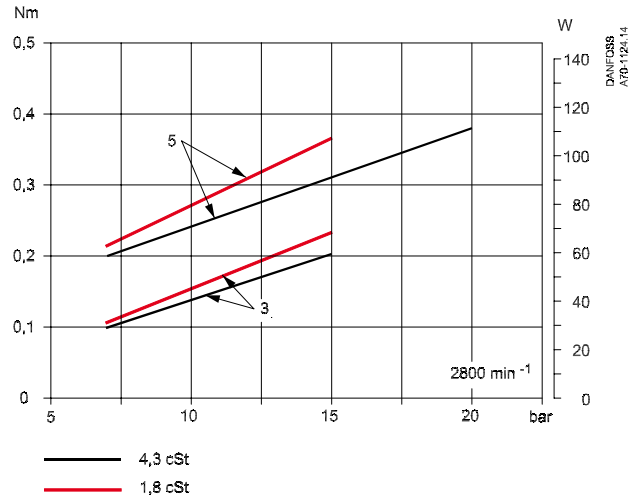

## Dimensions

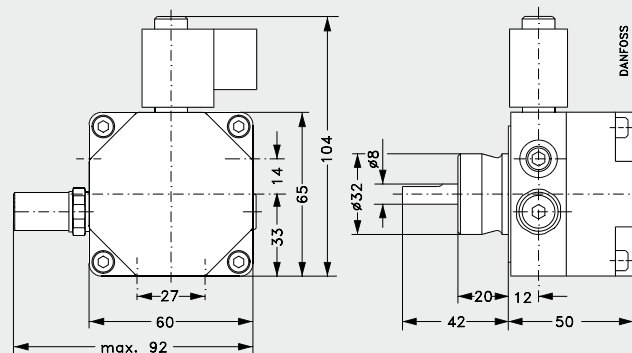

Danfoss can accept no responsibility for possible errors in catalogues, brochures and other printed material. Danfoss reserves the right to alter its products without notice. This also applies to products already on order provided that such alterations can be made without consequential changes being necessary in specifications already agreed. All trademarks in this material are property of the respective companies. Danfoss and the Danfoss logotype are trademarks of Danfoss A/S. All rights reserved.