

OIL BURNERS

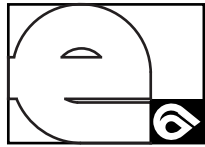

Ecoflam

techniques for energy saving



ISO 9001
registered by
GASTEC

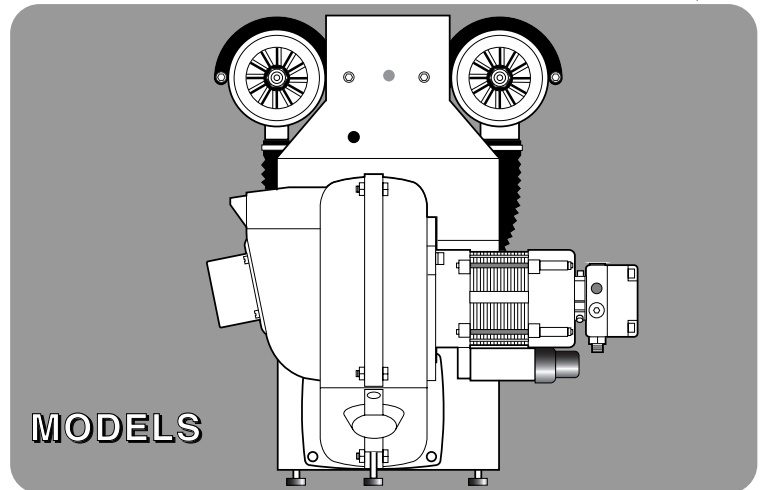

AGA Twin-Head 480

Gas oil

Cooker - Boiler

230V - 50Hz



LB909

03.05.2002

TECHNICAL DATA

MODEL AGA TWIN-HEAD		480
Voltage single phase 50 Hz	V	240
Motor	W	130
Rpm	Nº	2800
Capacitor	µF	3
Ignition transformer	kV/mA	15/40 EBI
Control box	SATRONIC	DKO974
Fuel :Gas oil	MJ/kg	45.5

OVERALL DIMENSIONS

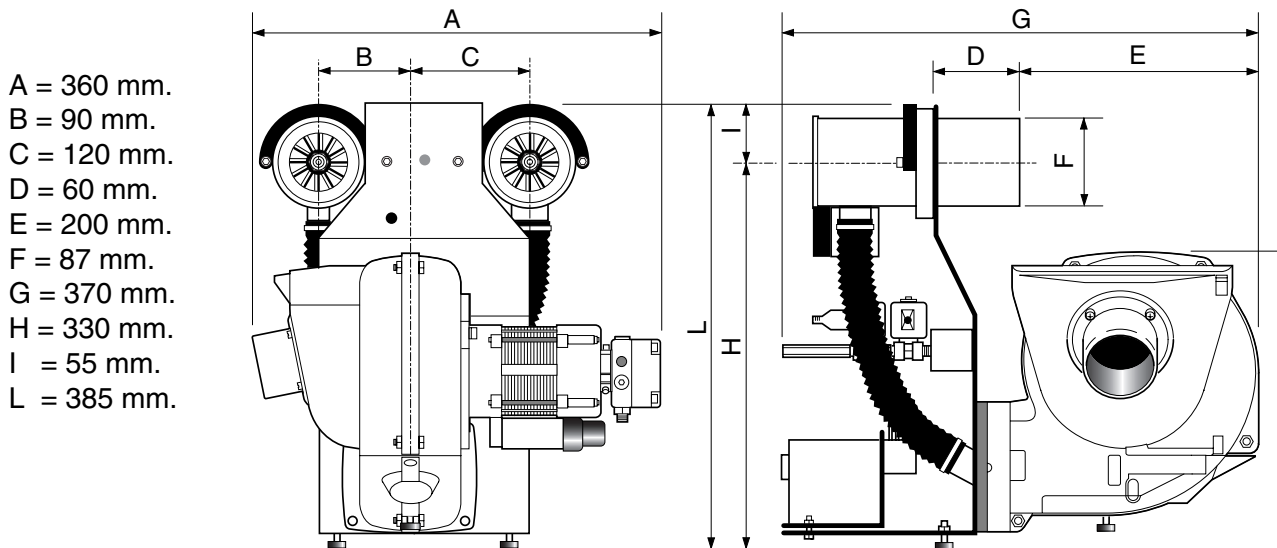

MAXIMUM LENGTH OF SUCTION LINES FOR TWO-PIPE SYSTEM

The correct length of pipes is calculated by summing up the length of all vertical and horizontal right sections and bends. The static suction head will be the distance between the non-return valve and the burner's pump axle.
 The depression must not be greater than 0.45 bar; should it be higher, some damage could occur to the pump, with consequent increase in mechanical noises and ,eventually, a failure.

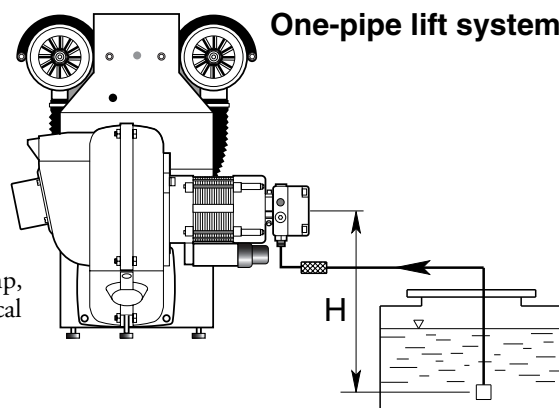

Head H on the pump (m)	Copper pipe	
	8 mm	10 mm
0,5	23	55
1	21	50
1,5	19	45
2	17	40
2,5	14	34
3	9	28
3,5	4	22

NOZZLE OUTPUT

Models:	NOZZLE		PUMP PRESSURE
	GPH	SPRY	PSI
AGA Twin-Head			
480 cooker	0.40	80°EH	130
480 boiler	0.6	80°S	130

PRIMING AND ADJUSTMENT OF THE PUMP

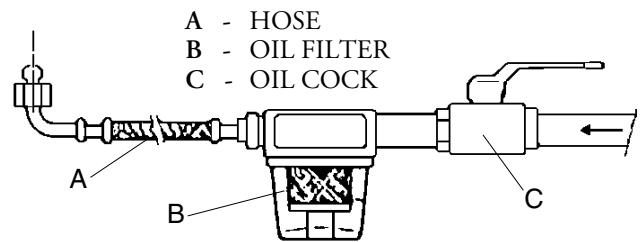
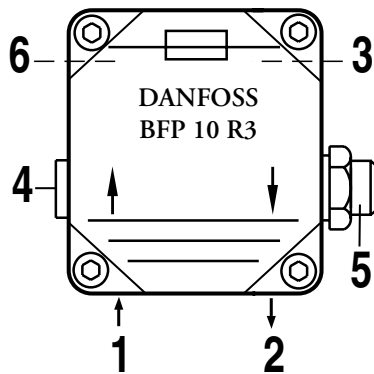

- 1 - INLET
- 2 - RETURN
- 3 - BLEED AND PRESSURE GAUGE PORT
- 4 - VACUUM GAUGE PORT
- 5 - PRESSURE ADJUSTMENT
- 6 - TO NOZZLE

The pump is adjusted during testing and inspection to 130 PSI. Gas oil only

The pump setting indicated by client is carried out in the factory during testing. To prime the pump first of all start the burner and bleed air from the pump through the gauge port. If the burner goes to lock-out after the prepurging time due to lack of pressure in the oil pump, restart the burner.

NOTE :

Before starting up the burner, make sure that the return pipe is clear. Check that the pipes do not leak. It is advisable to use copper pipes. Do not exceed the depression limit of 4 mt.(0,45 bar) to keep low noise levels. The return pipe must reach the same level as the check valve at the bottom of the oil tank..

VERIFY:

- That piping system is perfectly sealed;
- That the use of hoses is avoided whenever is possible (use copper pipes preferably);
- That depression is not greater than 0,45 bar, to avoid pump's cavitation;
- That check valve is suitably designed for the duty;

The pump pressure is set at a value of 130 PSI (Gas oil only) during the testing of burners. Before starting the burner, bleed the air in the pump through the gauge port. Fill the piping with light-oil to facilitate the pump priming. Start the burner and check the pump feeding pressure. In case the pump priming does not take place during the first prepurging, with a consequent, subsequent lock-out of the burner, rearm the burner's lock-out to restart, by pushing the button on the control box. If, after a successful pump priming, the burner locks-out after the prepurging, due to a fuel pressure drop in the pump, rearm the burner's lock-out to restart the burner. Do not allow the pump to work without oil for more than three minutes.

NOTE:

Before starting the burner, check that the return pipe is open. An eventual obstruction could damage the pump sealing device.

NOZZLE REPLACEMENT

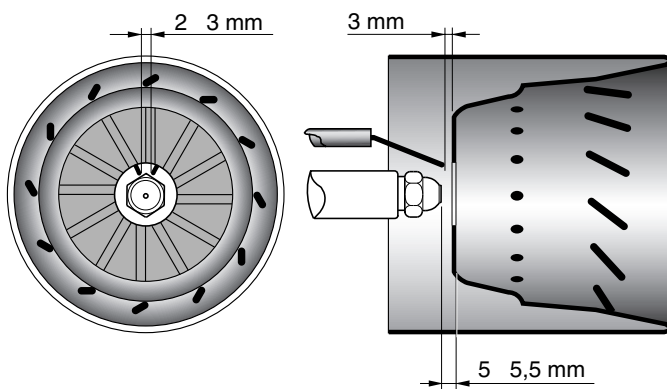

Remove the nozzle carefully taking great care not to damage the electrodes. Fit the new nozzle with the same care.

NOTICE : Always check the position of the electrodes after replacing the nozzle(see plan).

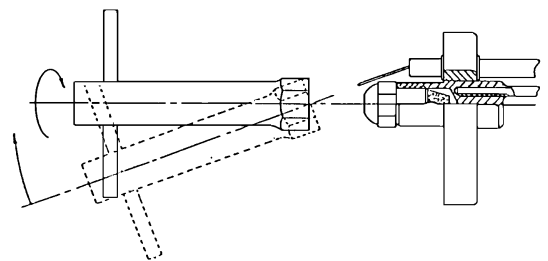

BURNER START-UP

- * Once connected the hoses to the oil pipes make sure that there are no leakages.
- * Air bleed the pipe through the pump operating on the gauge connection (see fig.).
- * Install the suitable nozzle for the needed capacity.
- * Turn thermostat to the desired temperature.
- * The burner will purge for about 13 sec.
- * At this point the oil valve opens and the transformer ignites.
- * Control the pressure on the pump. (see fig.).
- * Adjust the needed quantity of air, operating on the air regulator.
- * In case of no ignition the burner goes to lock-out within 10 sec.

AIR REGULATION

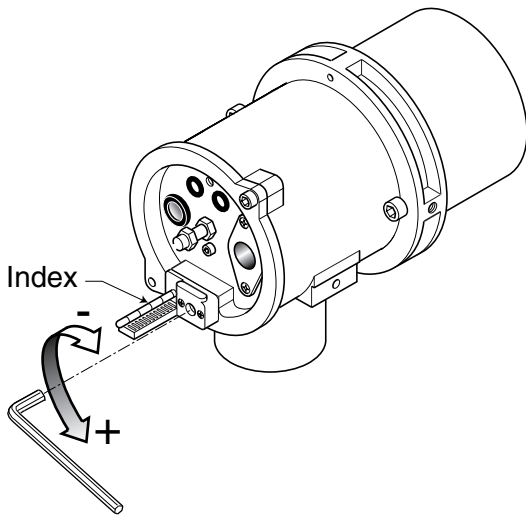

BLAST TUBE DISASSEMBLY

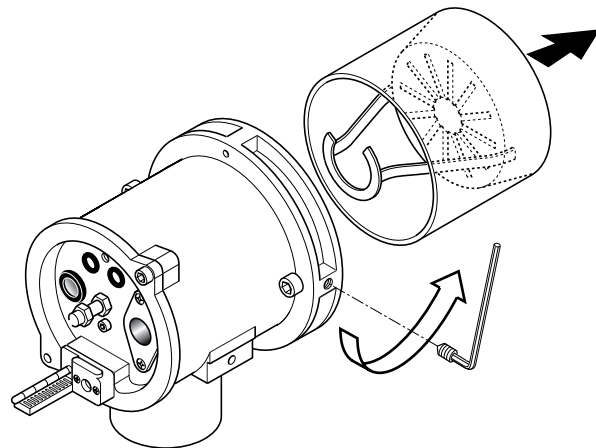

POSITIONING OF THE BURNER INSIDE THE COOKER

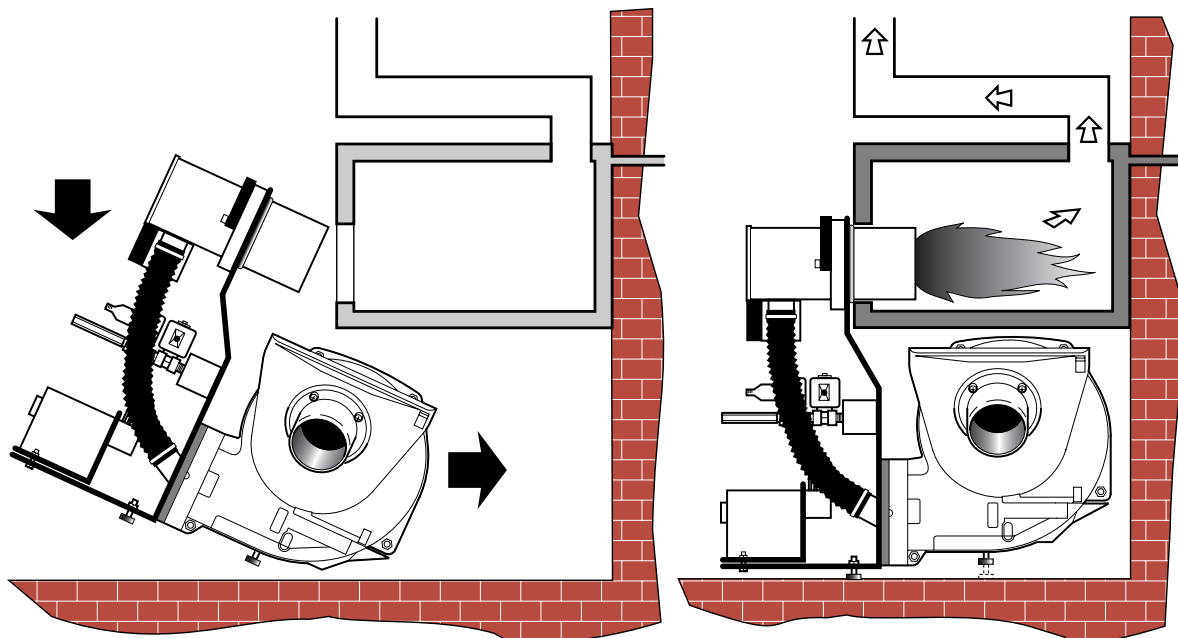

FAULT FINDING

Burner does not start up

- Mains switch not on. - Blown fuse. - Boiler thermostats not made. - Fault in control box.

Burner pre-purges and stops

- Fault in control box.

Burner does not ignite during cycle and stops

- Fault in control box. - Fault in photo-resistor.

Burner does not ignite

- Dirty ignition electrodes. - Fault at electrodes. - Electrodes installed wrongly. - Fault ignition transformer. - Blocked nozzle. - Nozzle needs replacing. - Oil pressure too low. - Blocked oil filter. - Excessive combustion air for nozzle capacity. - Fault in control box.

Burner ignites and then stops

- Faulty nozzle. - Photo-resistor does not "see" flame. - Excessive combustion air for nozzle capacity. - Fault in control box. - Oil pressure too low. - Blocked oil filter.

"AGA" Twin-Head 480

Gas Oil

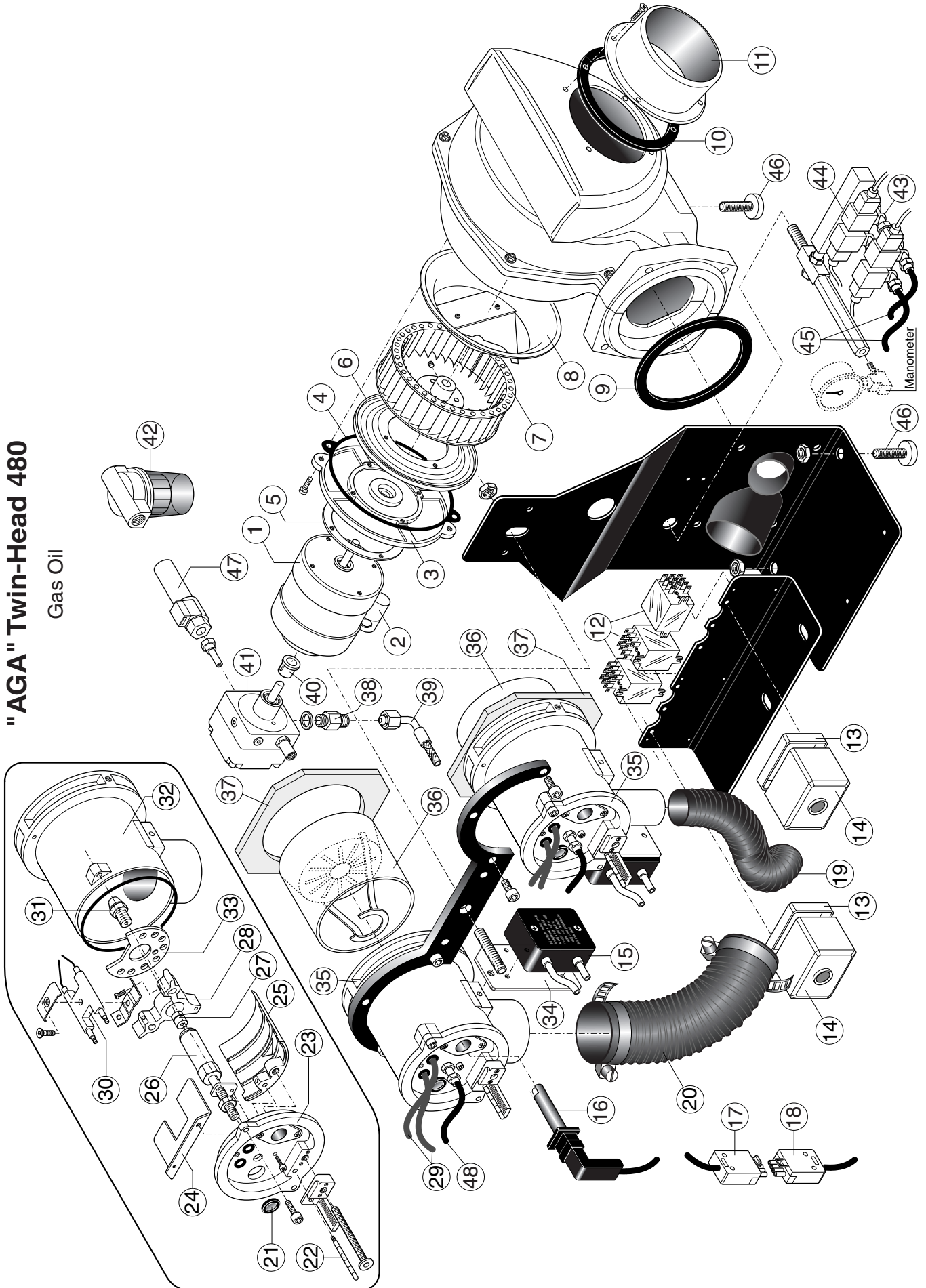

N°	DESCRIPTION: AGA Twin-Head Boiler/Cooker	480 code
1	MOTOR 130 W	M181/32
2	CAPACITOR 3 µF	C107/9
3	FLANGE	L181/16
4	BLACK O-RING	BFG01025
5	GASKET AIR CONVEYOR TO MOTOR	BFG01005/3
6	AIR CONVEYOR TO MOTOR	BFC08403/001
7	FAN Ø 145 x 50	W117
8	FAN SCOOP AIR CONVEYOR	BFC08401/001
9	GASKET	BFT11510
10	GASKET	CFG01010
11	FLANGED EXTERNAL AIR INTAKE	CFA02009/001
12	FINDER RELAY	R733/2
13	CONTROL BOX BASE SATRONIC	A416
14	CONTROL BOX SATRONIC DKO 974	A156/4
15	IGNITION TRANSFORMER 15/40	T130
16	PHOTORESISTOR SATRONIC	A214
17	WIELAND PLUG 4 POLES	E222
18	WIELAND SOCKET 4 POLES	E223
19	COOKER CORRUGATED HOSE Ø 40	S951/3
20	BOILER CORRUGATED HOSE Ø 60	S951/4
21	GLASS ASSEMBLY	GRV1S001
22	INDEX	BFT11509
23	HEAD HOLDER DISC	BFT11518
24	FLAP	BFT11504/001
25	AIR DAMPER	BFT11519/2
26	NOZZLE HOLDER	BFT11507/151
27	CUT-OFF VALVE DANFOSS	V195
28	NOZZLE HOLDER SUPPORT	BFT11514
29	IGNITION CABLES	BFE01401/7
30	IGNITION ELECTRODES SET	BFE01102
31	BOILER NOZZLE DANFOSS	U1060/80S
	COOKER NOZZLE DANFOSS	U1040/80EH
32	BOILER HEAD HOLDER PIPE	BFT11522/2
	COOKER HEAD HOLDER PIPE	BFT11522/1
33	COOKER REAR DISC	BFD01012/001
	BOILER REAR DISC	-
34	SUPPORT IGNITION TRANSFORMER	BFT11521/001
35	BOILER INNER ASSEMBLY	GRTT0100/910
	COOKER INNER ASSEMBLY	GRTT0100/900
36	BOILER BLAST TUBE	BFB01014/051
	COOKER BLAST TUBE	BFB01009/2
37	GASKET	Y105
38	NIPPLE	BFR01103/001
39	HOSES	S952/13
40	COUPLING	MP504
41	PUMP MOTOR DANFOSS BFP10R3	P121/8
42	OIL FILTER	S117/8
43	OIL VALVE PARKER VE131 IN	V175/8
44	COIL PARKER	V516/4
45	HOSES	S951/5
46	ANTIVIBRATION DAMPER	E538/2
47	PRE HEATER DANFOSS FPHB5	PP110



DESIGN AND SPECIFICATIONS SUBJECT TO CHANGE WITHOUT NOTICE

Ecoflam (UK) Limited

*12 Goodwood Road , Keytec 7 Business Park, Wyre Road, Pershore, Worcestershire, WR10 2JL England
Tel: 01386 556092 - Fax: 01386 553789*

Ecoflam S.p.A.

via Roma, 64 - 31023 RESANA (TV) - Italy - tel. 0423/715345 r.a. - telex 411357 ECOFLA I - telefax 0423/715444